

Pressure Transmitter

MPS500



OVERVIEW

Operation

MPS500 series pressure transmitters are suitable for liquids, gas pressure measuring and controlling in the moderate media, with sensor probe working very well with long term stability at the high temperature of 125 °C

Features

- Compact design
- Protection type IP65 or IP67 as optional
- Corrosion resistant stainless steel design
- Wide measuring range
- Simple installation
- Various output signal

Application

- Creating consumption profiles to save energy
- Pressure and temperature-compensated flow measurement of compressed air
- Accurate determination of compressed air flow rates over a broad measuring range

OPERATING DATA

Temperature Limit	-40...125°C
Compensated Temp. Limit	0...100°C
Stability	0.15% of FS/year
Accuracy	±0.5% FS for MPS500 ±0.2% FS for MPS501 ±0.1% FS for MPS502
Over Pressure	Full scale range up to 16 bar-2.5x Above 16 to 600bar - 2x Above 600 bar - 1.5x
Zero Balance	±5 % Full scale

MEASURING RANGES

Max Pressure Range 0-2500 bar

MATERIALS

Wetted Parts	AISI316L
Body Tube	AISI304
Others	On request

ASSEMBLY DRAWINGS

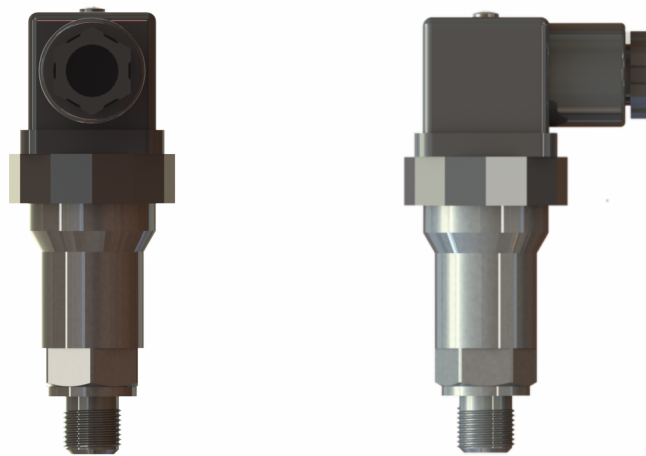

■ INSTALLATION

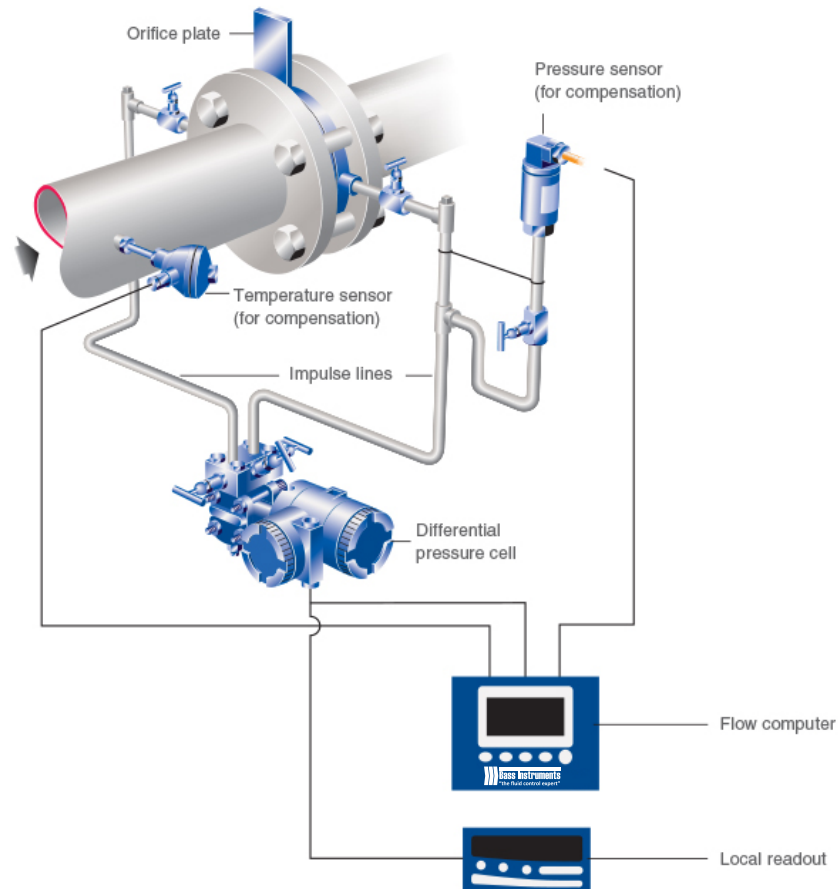

1. Select the Right Gauge

Before you pull out a wrench, first make sure you have the right type of gauge for the application. The pressure gauge you choose must be the correct one for the:

- Expected pressure range to be measured. The selected range should be double the operating range.
- Process media compatibility.
- Process temperature
- Severe operating conditions (e.g., vibrations, pulsations, pressure spikes).
-

However, even if you install the gauge perfectly, you could face the same problems you had before the installation if the gauge isn't the right one for the job.

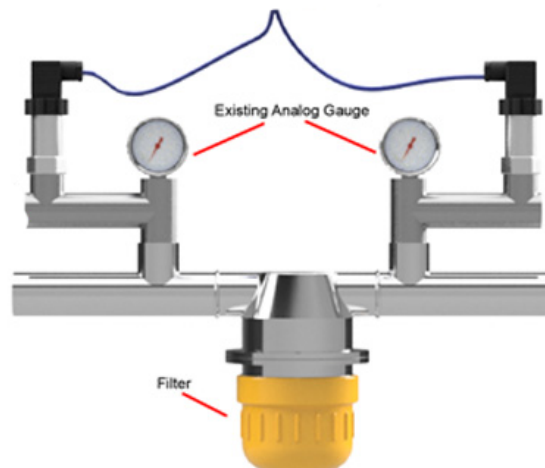

2. Apply Force on Wrench Flats

Once you've chosen the correct gauge, pay attention to how you install the gauge. Rather than turning the case by hand, use an open-end wrench and apply force to the wrench flat. Applying the force through the case could damage the case connection as well as the gauge internals. Not applying sufficient torque could result in leaks.

3. Seal the Deal

Notice the type of threads on the gauge before you seal it. If the gauge has parallel threads, seal it using sealing rings, washers. If the gauge has tapered threads, additional means of sealing, such as PTFE tape, are recommended. This is standard practice for any pipe fitter because tapered threads do not provide complete sealing on their own.

4. Use a Clamp Socket or Union Nut with Straight Thread

When tapered threads are used, the installer has the luxury of adjusting the gauge even after sufficient torque has been applied. This allows for convenient orientation of the gauge face. However, with straight threads the face orientation is not adjustable once it bottoms out. You start by tightening the gauge by hand. As soon as you encounter a resistance, apply an open-end wrench to the wrench flat and continue turning the gauge. At this point you have approximately one turn left to put the gauge into the desired position.

5. Leave Space for Blow-out

For personnel safety, some gauges come with a safety pattern design consisting of a solid wall between the front of the gauge and the Bourdon tube, and a blow-out back. In the event of a pressure build-up inside the case or a catastrophic Bourdon tube rupture, all the energy and release of media will be directed to the back of the gauge, thus protecting the people reading the gauge. In order for the safety device to function properly, it is important to keep a minimum space of 1/2 inches. Process gauges come standard with integrated pegs to insure this distance when mounting the gauge against a surface.

6. Vent the Gauge Case

Some gauges come with a small valve on top of the case. Users who don't understand the purpose of the valve are confused about why it's included. During shipment, liquid-filled gauges can go through temperature changes that create internal pressure build-up. This can cause the gauge pointer to be off zero. When installing the gauge, open the compensation valve to allow this pressure to vent. It should then be closed again to prevent any external ingress. After you mount the gauge, set the compensating valve from CLOSE to OPEN.

A pressure gauge can do its job only if it's installed properly. Whether you're an operator or a maintenance technician, use these tips for proper gauge installation to make sure your gauges perform as they should. Contact Bass Instrument's technical support team if you have questions about properly installing gauges.

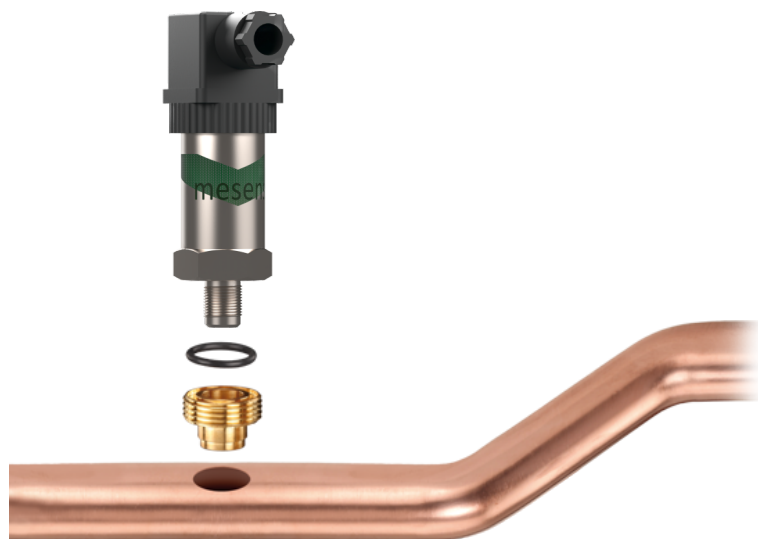

■ TECHNICAL DRAWINGS AND DIMENSIONS

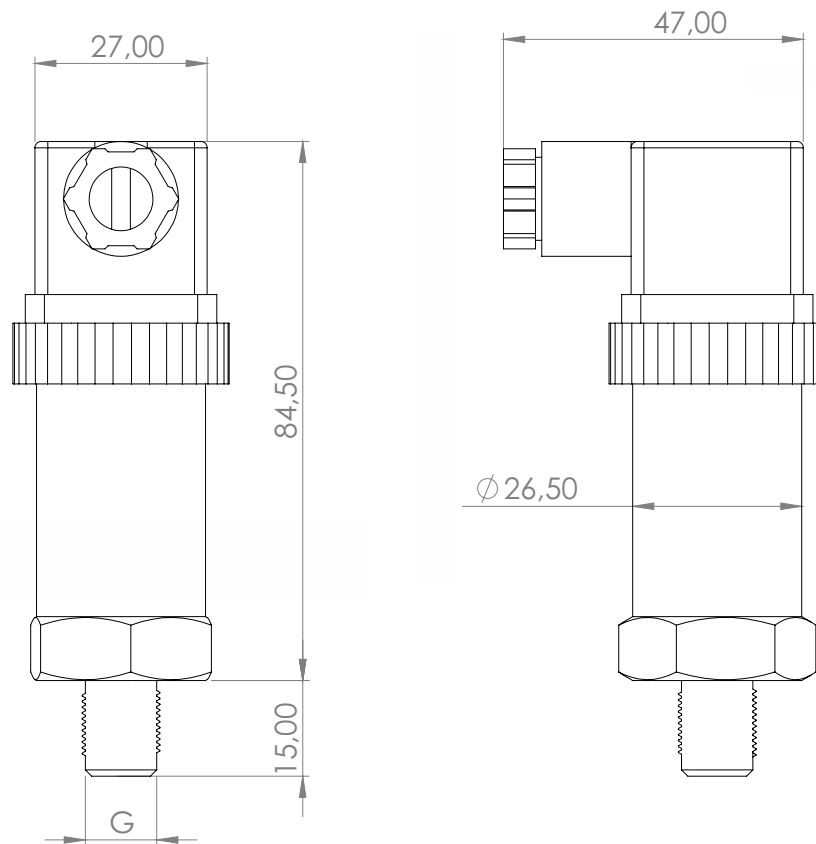

■ CONNECTION

Standart
Others

1/4", 1/2", 3/4", 1" NPT or G
On request

■ ELECTRICAL DATA

Output	2 wires, 4-20 mA
Power Supply	10-36 VDC power
Option	0-5 VDC, 1-5 VDC or 0-10 VDC Supply should be 14 VDC min.
Electrical Connection Others	DIN 43650A or cable connection, on request
Enclosure	IP65, IP67 and IP68 on request

■ WIRING

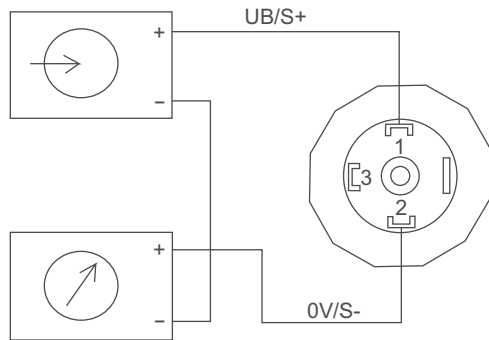

4-20 mA, 2 wires

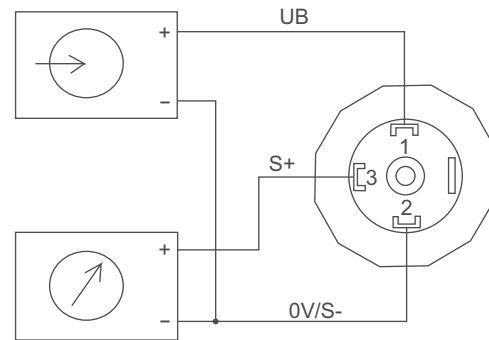

0-10 VDC

■ MEASURING RANGES

Code	Range	Code	Range	Code	Range
001	0...25 mBar	010	0...1.6 Bar	019	0...100 Bar
002	0...40 mBar	011	0...2.5 Bar	020	0...160 Bar
003	0...60 mBar	012	0...4 Bar	021	0...250 Bar
004	0...100 mBar	013	0...6 Bar	022	0...400 Bar
005	0...160 mBar	014	0...10 Bar	023	0...600 Bar
006	0...250 mBar	015	0...16 Bar	024	0...1000 Bar
007	0...400 mBar	016	0...25 Bar	025	0...1600 Bar
008	0...600 mBar	017	0...40 Bar	026	0...2500 Bar
009	0...1 Bar	018	0...60 Bar	XXX	Special Ranges

ORDERING

MPS500					Pressure Transmitter
Output	420				4-20 mA (others specify as X)
	050				0-5 VDC
	010				0-10 VDC
Measuring Range		XXX			Please Look at Measuring Range Table
Pressure Type			01		Relative
			02		Absolute
Process Connection			01		G 1/2" (please specify other size as X)
			02		1/2" NPT-M
			03		G 1/4"
			04		1/4" NPT-M
Electrical Connection				PIN	Pin Connector M12
				DIN	DIN 43650A
				010	Cable length 10m.
Hazardous Area				N	None
				Xi	II 1/2G Ex ia IIC T4 Gb(Ga)